

# SL-T0603PTC020-L55-A

## DATA SHEET

SPEC. NO. : SZ20073001  
DATE : 2020/07/30  
REV. : A/0

Approved By:

Checked By:

Prepared By:







## Typical Electrical / Optical Characteristics Curves (25 W Ambient Temperature Unless Otherwise Noted)

FIG.1 Relative Response vs. Wavelength

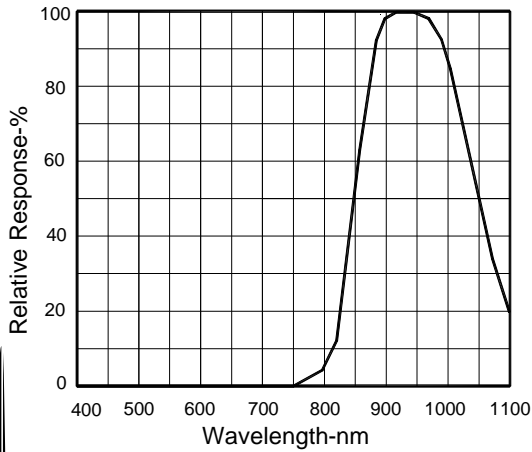

FIG.2 Power Dissipation Vs. Ambient Temperature

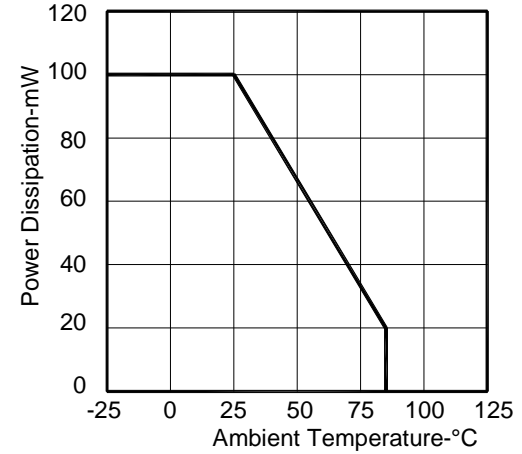

FIG.3 Rise And Fall Time Vs. Load Resistance

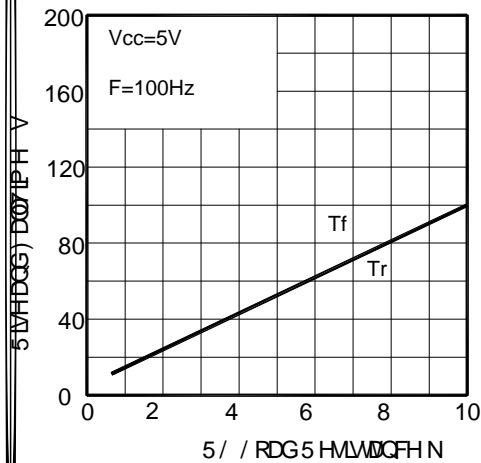

FIG.4 Relative Collector Current Vs. Irradiance

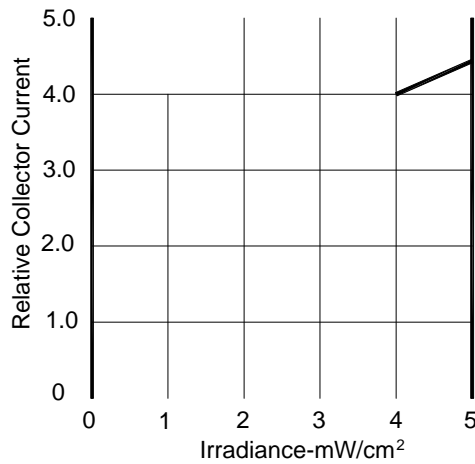
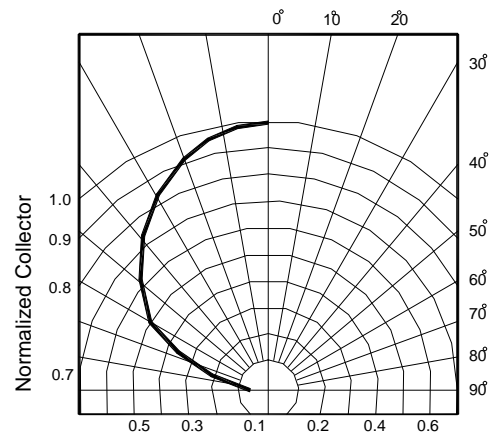
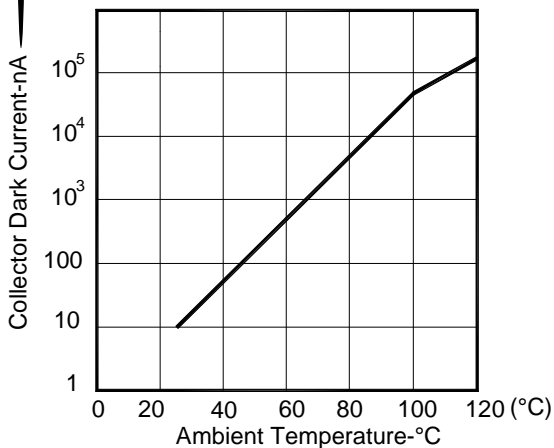
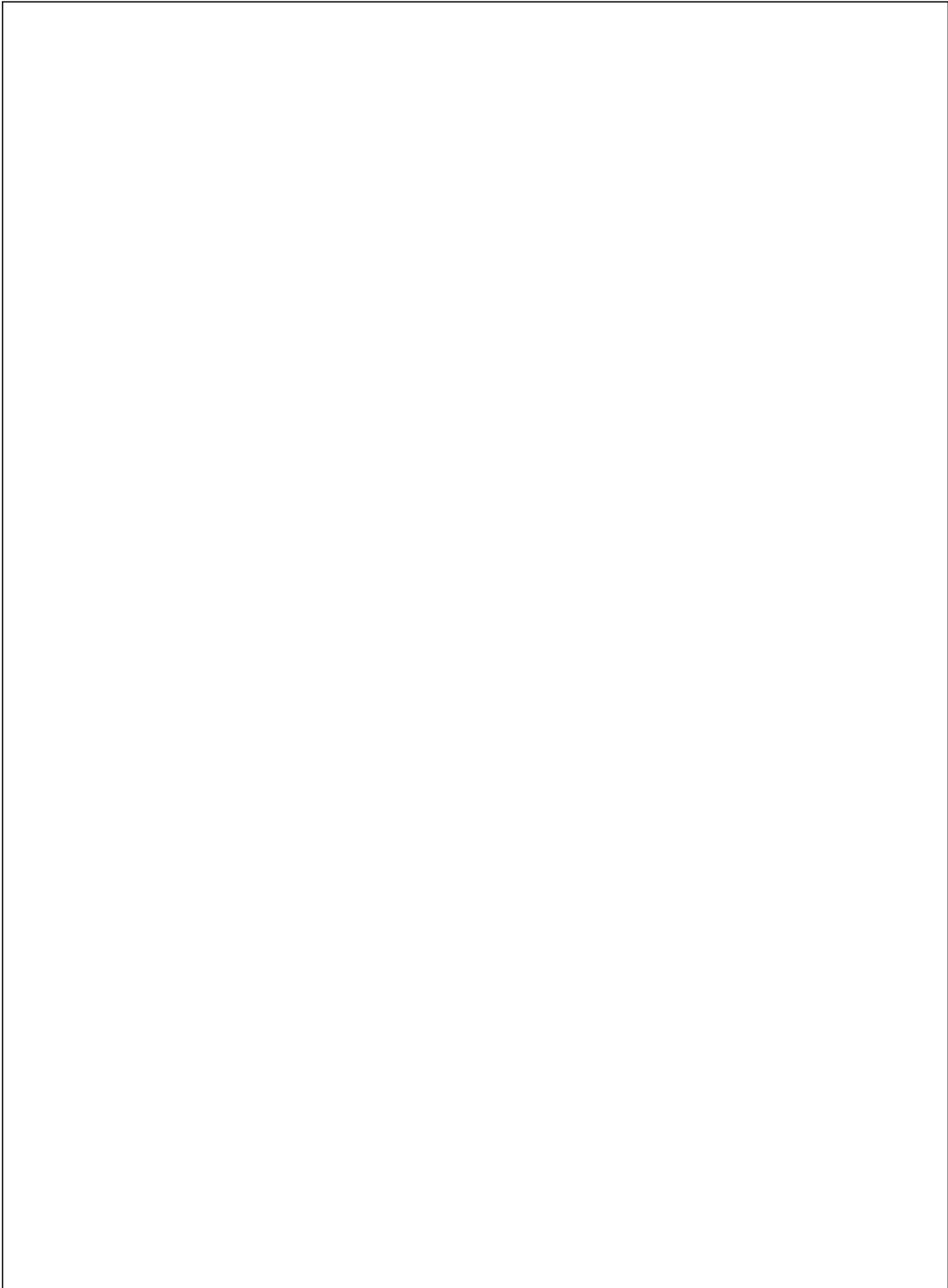

FIG.5 Collector Dark Current Vs. Ambient Temperature







## Carrier Tape Specifications (Loaded Quantity: 5000pcs/reel)

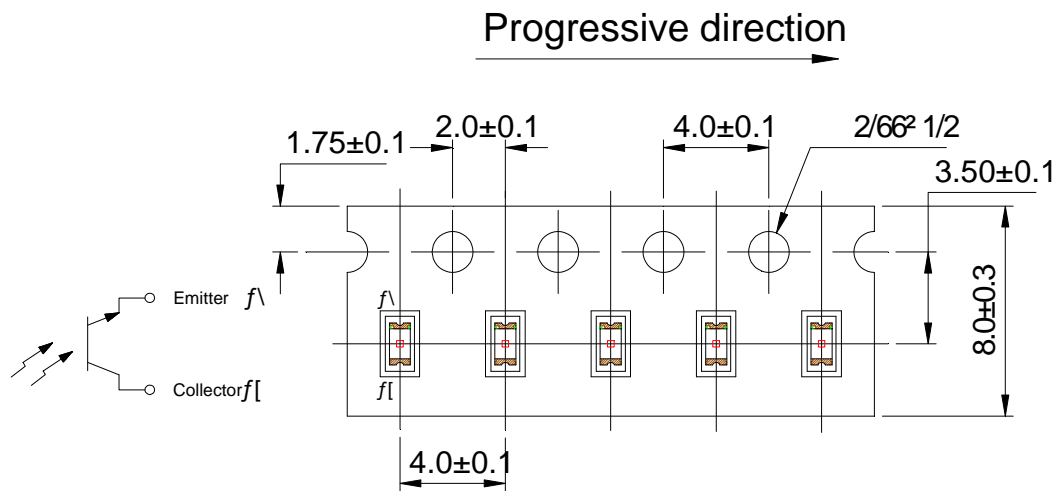

Note: Tolerance unless mentioned is  $\pm 0.1$ mm; Unit = mm

## Moisture Resistant Packaging

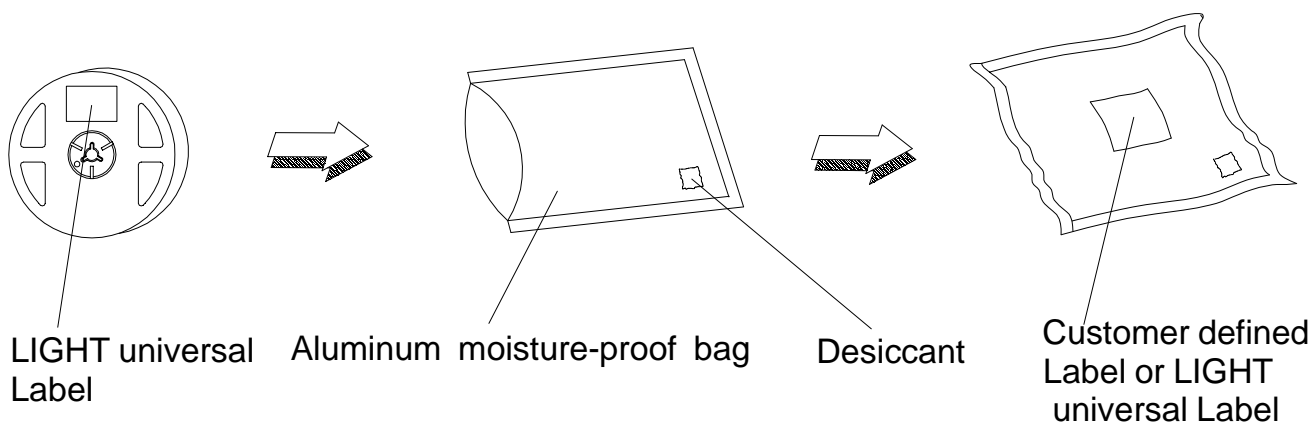



## Suggest IR Reflow Condition For Lead Free

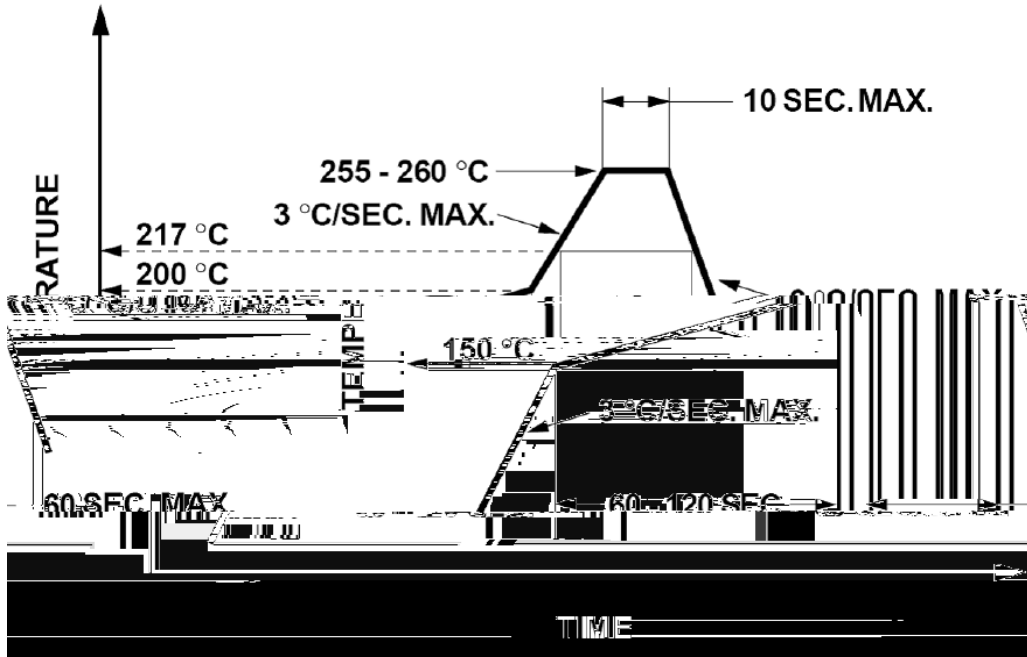

1. Reflow soldering should not be done more than two times.
2. When soldering, do not put stress on the LEDs during heating.

## Soldering iron

1. When hand soldering, the temperature of the iron must less than 300 seconds
2. The hand solder should be done only once.

## Repairing

Repair should not be done after the LEDs have been soldered. When repairing is unavoidable, a double-head soldering iron should be used (as below figure). It should be confirmed beforehand whether the characteristics of LEDs will or will not be damaged by repairing.

